

**LE SUEUR COUNTY HIGHWAY DEPARTMENT**  
**Application For Access Driveway or Entrance Permit**

C.S.A.H./Co. Hwy. No. \_\_\_\_\_ Name of Twp. \_\_\_\_\_

Name of Applicant: \_\_\_\_\_ Telephone No.: \_\_\_\_\_

Address: \_\_\_\_\_

Name of Property Owner: \_\_\_\_\_ Telephone No.: \_\_\_\_\_

Address: \_\_\_\_\_

Location: Co. Hwy. No. \_\_\_\_\_ in Le Sueur Co. \_\_\_\_\_ miles N-S-E-W of \_\_\_\_\_  
(circle one) (Specify nearest road intersection)

Parcel ID # \_\_\_\_\_

Legal Description of Property \_\_\_\_\_

Purpose of Driveway: Residence \_\_\_\_\_ Field \_\_\_\_\_ Other \_\_\_\_\_

Is a building to be constructed: Yes \_\_\_\_\_ No \_\_\_\_\_ What kind \_\_\_\_\_

Will the building be: Temporary \_\_\_\_\_ Permanent \_\_\_\_\_

Distance from center of highway to front of building is \_\_\_\_\_ feet.

Is land higher? \_\_\_\_\_ lower? \_\_\_\_\_ or level? \_\_\_\_\_ with highway.  
(feet or inches) (feet or inches)

Number of present driveways onto parcel \_\_\_\_\_

Distance to nearest existing entrance/access on same side of road: Greater than 500 feet or \_\_\_\_\_ feet.

Date Proposed driveway will be needed \_\_\_\_\_

Give exact location to proposed driveway to property: (Place stake/marker to locate center of proposed driveway)  
ATTACH SKETCH OF PROPERTY, PRESENT AND PROPOSED DRIVEWAY AND RELATION TO COUNTY HIGHWAY

I, We, the undersigned, herewith make application for permission to construct the access driveway at the above location, said driveway to be constructed to conform with the standards of the Minnesota Highway Department and to any special provisions included in the permit. It is agreed that all work will be done to the satisfaction of the Le Sueur County Highway Department (Road Authority). It is further agreed that no work in connection with this application will be started until the application is approved and the permit issued.

Access drives onto any public roads shall require a review by the Road Authority. The Road Authority shall determine the appropriate location, size, and design of such access drives and may limit the number of access drives in the interest of public safety.

(Continue)

Access drives which traverse wooded, steep, or open field areas shall be constructed and maintained to a minimum ten (10) foot width, base material depth sufficient to support access by emergency vehicles, have an unobstructed width of not less than fourteen (14) feet, and an unobstructed vertical clearance of not less than thirteen (13) feet, six (6) inches. Access drives outside the road right of ways shall not exceed twelve percent (12%) grade unless approved by local fire chief.

Access drives shall have a twenty (20) foot long flat grade directly adjacent to the road that drive accesses.

All lots or parcels with dwellings shall have direct adequate physical access for emergency vehicles along the frontage of the lot or parcel from either an existing or dedicated public roadway.

All roads serving more than one (1) lot or parcel with dwellings shall be built to township road specifications or at least sixty six (66) feet wide with a minimum driving surface width of twenty-four (24) feet.

Access drive lengths in excess of one hundred fifty (150) feet shall provide a minimum turn-around of forty (40) feet in width by forty (40) feet in length.

BE IT RESOLVED: That the County Highway Engineer is hereby authorized and instructed to control farm and field entrances on all County State Aide Highways, including roads scheduled for new construction, under the following regulations.

- A. One field and one farm entrance shall be allowed per owner or approved additional access at no cost to owner.
- B. A permit shall be required on all additional entrance requests.
- C. All new culverts and aprons on additional entrance requests shall be furnished by the private owner, and constructed according to the Engineer's specifications.
- D. All new culvert materials and aprons shall become the property of the County Highway Department and entrances shall be maintained by same.
- E. There shall be no distinction for entrances with or without culvert.
- F. The relocation of existing entrances shall be accomplished at the private owner's expense and according to the Engineer's specifications, except where the County is proved negligent.

BE IT RESOLVED: That the design standards for County Roads be the same as those currently listed in State Aid Rules for County State Aid Highways.

\_\_\_\_\_  
Date

\_\_\_\_\_  
Signature of Applicant

**Office Use Do Not Write On This Page**

**\*\*\*NOT VALID UNLESS SIGNED AND NUMBERED\*\*\***

Access Driveway or Entrance Permit: \_\_\_\_\_  
Permit Number

Permission is hereby granted for the construction of the driveway as described in the above application, said driveway to be constructed in accordance with the Minnesota Highway Department Driveway Standard Plate No. 9000E (next page) and subject to the requirements of the following special provisions.

SPECIAL PROVISIONS:

It is expressly understood that this permit is conditioned upon replacement or restoration of the County Highway to it original or to satisfactory condition.

\_\_\_\_\_  
Date

\_\_\_\_\_  
Le Sueur County Highway Engineer

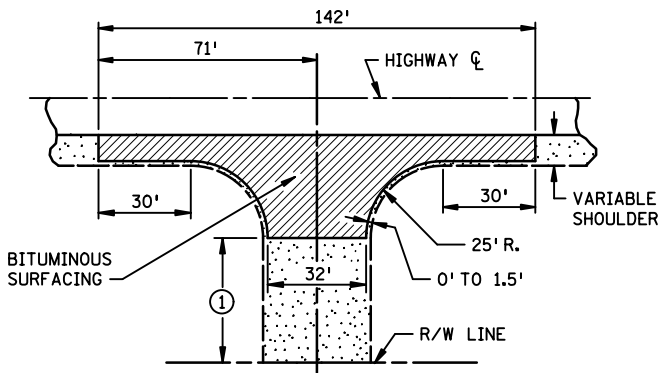

COMMERCIAL - INDUSTRIAL - FARM ENTRANCES

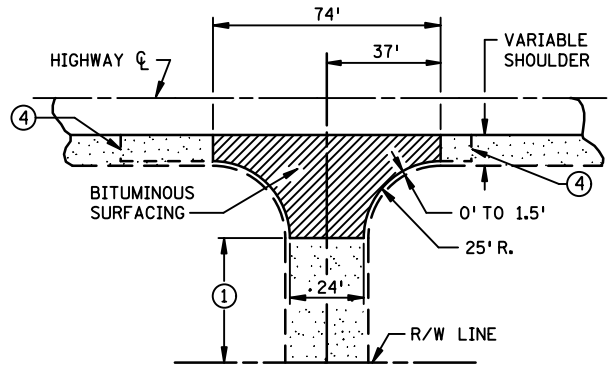

RURAL RESIDENTIAL ENTRANCE

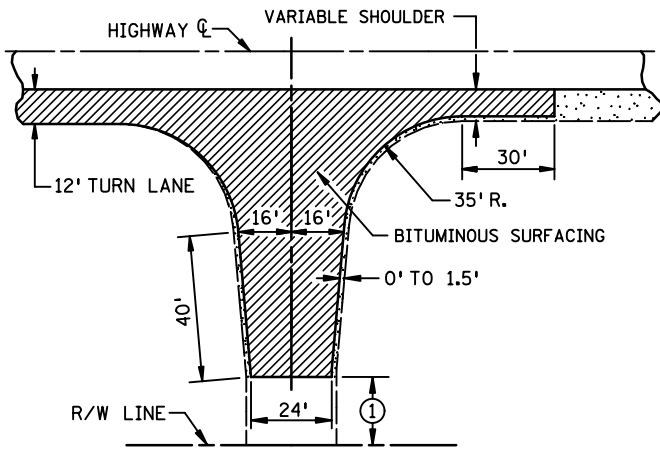

LOW VOLUME ROAD

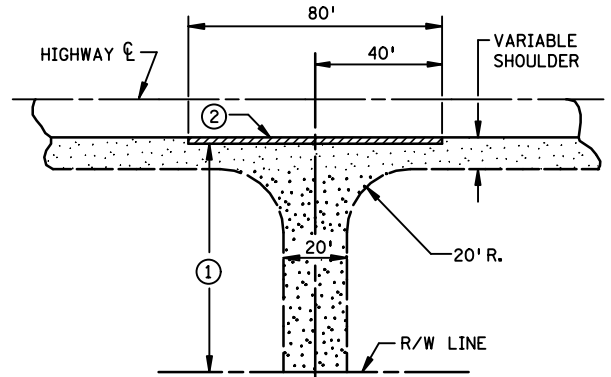

FIELD ENTRANCES

- ① SURFACING TO MATCH EXISTING CONDITIONS. WHERE THERE IS NO SURFACING, PLACE GRAVEL BEYOND BITUMINOUS SURFACING TO R/W LINE.
- ② PLACE 2 FT. WIDE BITUMINOUS SURFACING AS DIRECTED BY ENGINEER.
- ③ 8% MAXIMUM COMMERCIAL; 15% MAXIMUM RESIDENTIAL.
- ④ THE USE OF PAVING SIMILAR TO COMMERCIAL ENTRANCES MAY BE APPROPRIATE FOR SOME RESIDENCES - AS SHOWN IN PLANS OR DIRECTED BY THE ENGINEER.

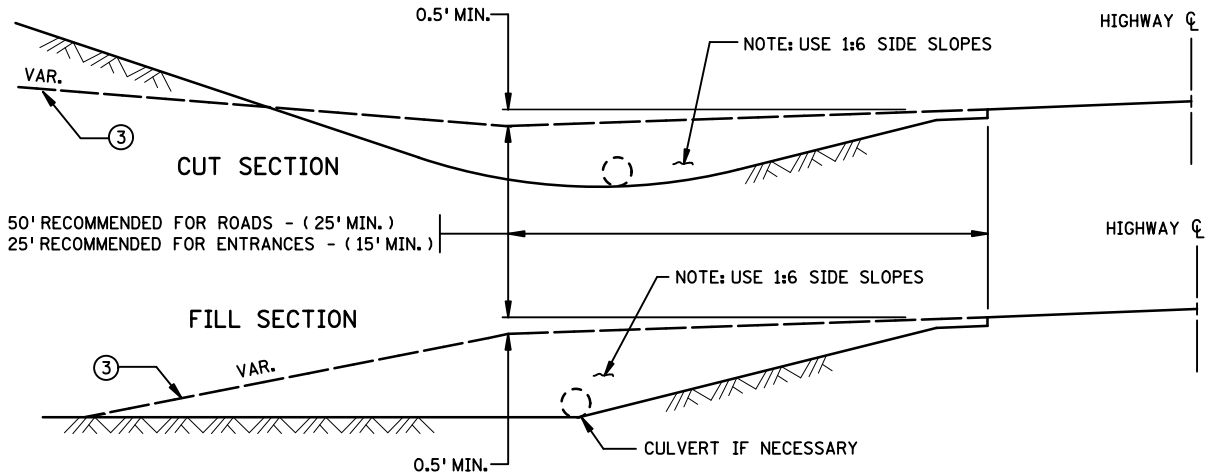

CROSS SECTIONS

APPROVED SEPT. 27, 2012

*Michael J. Henneman*  
STATE DESIGN ENGINEER

STATE OF MINNESOTA  
DEPARTMENT OF TRANSPORTATION

APPROACHES AND ENTRANCES

RECOMMENDED STANDARDS

SPECIFICATION  
REFERENCE

STANDARD  
PLATE  
NO.

9000E

LSC PERMIT # .....